

TURNBUCKLE JAW & JAW

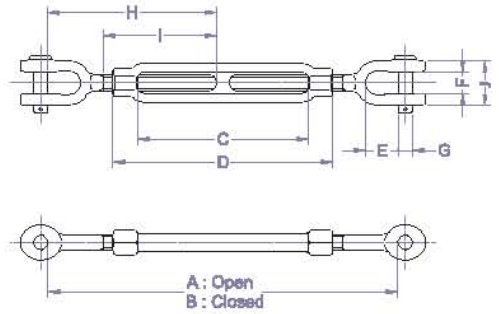

SPECIFICATION

Product Code	Size (inch)	SWL (WLL) (ton)	Dimension(mm)										Weight (kg)
			A	B	C	D	E	F	G	H	I	J	
TBJJ-001	3/8×6	0.5	402	260	152	180	22	14	8	130	97	29	0.4
TBJJ-002	1/2×6	1	434	294	152	188	27	16	10	147	103	34	0.7
TBJJ-003	1/2×9	1	586	370	229	265	27	16	10	185	141	34	1
TBJJ-004	1/2×12	1	739	446	305	341	27	16	10	223	179	34	1.2
TBJJ-005	5/8×6	1.6	468	332	152	198	33	19	13	166	109	43	1.2
TBJJ-006	5/8×9	1.6	620	408	229	275	33	19	13	204	147	43	1.6
TBJJ-007	5/8×12	1.6	773	484	305	351	33	19	13	242	185	43	1.8
TBJJ-008	3/4×6	2.4	489	356	152	208	38	25	16	178	116	52	1.9
TBJJ-009	3/4×9	2.4	642	432	229	285	38	25	16	216	154	52	2.5
TBJJ-010	3/4×12	2.4	794	508	305	361	38	25	16	254	192	52	2.9
TBJJ-011	3/4×18	2.4	1098	660	457	513	38	25	16	330	268	52	3.7
TBJJ-012	7/8×12	3.3	825	542	305	371	45	30	19	271	198	63	4.2
TBJJ-013	7/8×18	3.3	1129	694	457	523	45	30	19	347	274	63	5.5
TBJJ-014	1×6	4.5	553	426	152	228	53	35	22	213	128	71	4.5
TBJJ-015	1×12	4.5	858	578	305	381	53	35	22	289	204	71	6.2
TBJJ-016	1×18	4.5	1162	730	457	533	53	35	22	365	280	71	7
TBJJ-017	1×24	4.5	1469	884	610	686	53	35	22	442	357	71	8.5
TBJJ-018	1-1/4×12	6.9	917	644	305	385	72	45	28	322	212	93	9.6
TBJJ-019	1-1/4×18	6.9	1221	796	457	537	72	45	28	398	288	93	11.9
TBJJ-020	1-1/4×24	6.9	1526	948	610	690	72	45	28	474	364	93	13.3
TBJJ-021	1-1/2×12	9.7	941	674	305	401	72	52	35	337	222	102	14
TBJJ-022	1-1/2×18	9.7	1245	826	457	553	72	52	35	413	298	102	17.1
TBJJ-023	1-1/2×24	9.7	1550	978	610	706	72	52	35	489	374	102	18.5
TBJJ-024	1-3/4×18	12.7	1329	916	457	570	87	60	41	458	310	124	26
TBJJ-025	1-3/4×24	12.7	1633	1068	610	722	87	60	41	534	386	124	29.6
TBJJ-026	2×24	16.8	1682	1122	610	738	96	66	51	561	405	134	42.1
TBJJ-027	2-1/2×24	27.2	1797	1250	610	790	115	76	57	625	440	157	84
TBJJ-028	2-3/4×24	34	1846	1306	610	790	116	92	70	653	440	174	99.4

- **Material**_ Forged carbon steel
- **Test Load**_ Proof Load = SWL(WLL)×2.5, Breaking Load = SWL(WLL)×5
- **Surface**_ Hot Dip Galvanized
- **Reference**_ American society of testing materials, ASTM F 1145
- **ET C**_ Available certificate of NDT (M/T, U/T), 3rd Inspection test report.
Special size, design and, another material will can supply as your requirement.